

THIS DRAWING IS UNPUBLISHED. RELEASED FOR PUBLICATION, 19
 © COPYRIGHT 19 BY AMP INCORPORATED. ALL INTERNATIONAL RIGHTS RESERVED.

LOC	DIST	P	F	REVISIONS				
				ZONE	LTR	DESCRIPTION	DATE	APPD
AF	50				E	REDRAWN PER 0710-0215-95	5/23/95	JR/PD

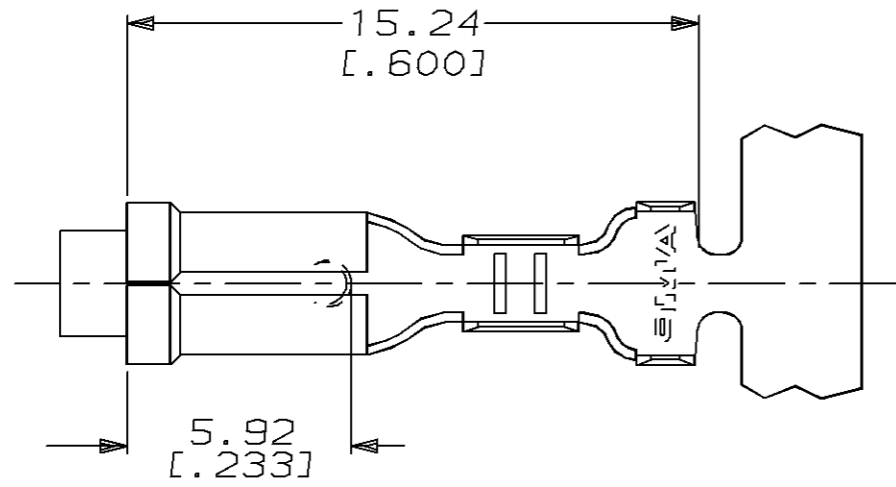

1 CONTINUOUS STRIP ON REELS.

2 TIN PLATE 0.002032
 [.000080] MIN THK.

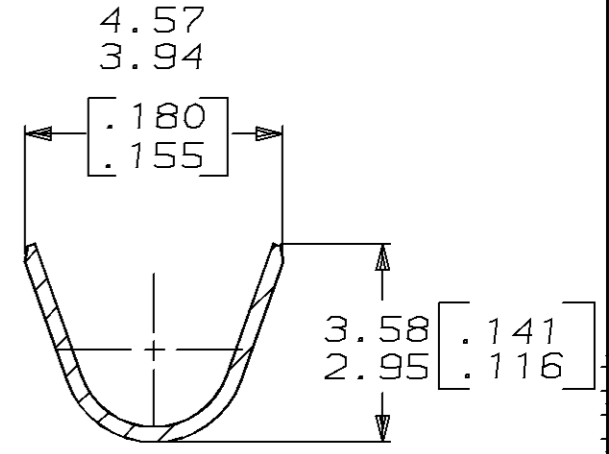
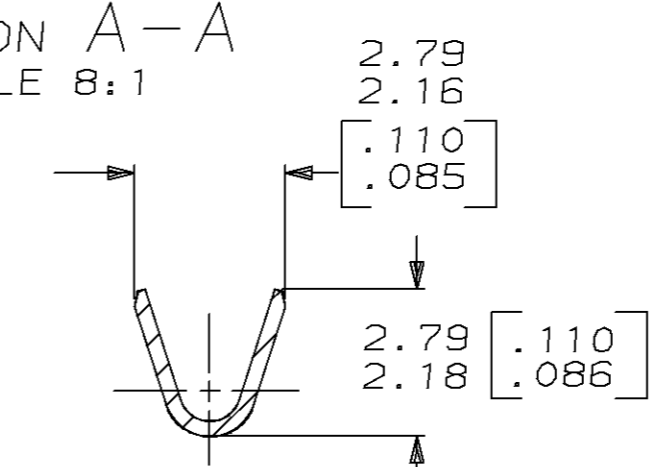
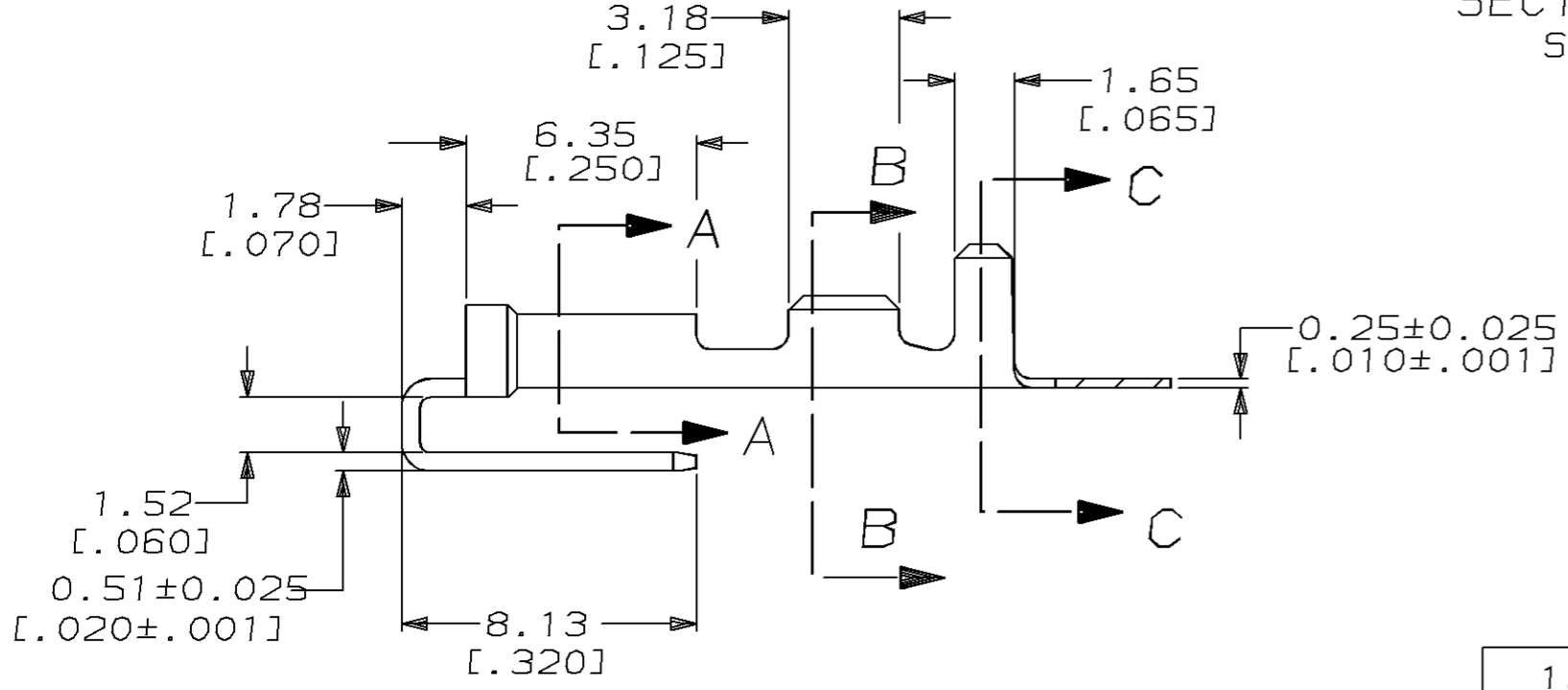
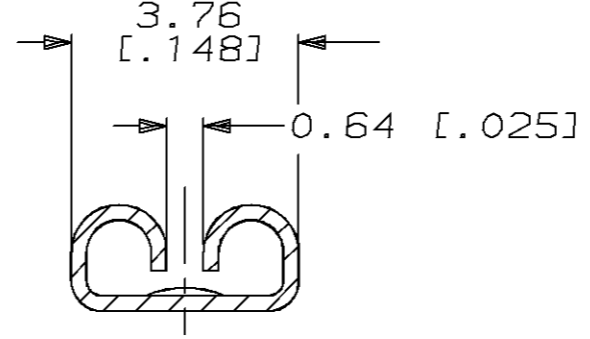

THIS DRAWING IS A CONTROLLED DOCUMENT FOR AMP INCORPORATED. IT IS SUBJECT TO CHANGE AND THE CONTROLLING ENGINEERING ORGANIZATION SHOULD BE CONTACTED FOR THE LATEST REVISION.

1.52-2.54 DIA [.060-.100] DIA	[#22-#18] AWG	0.508±0.025 [.020±.001]	TIN Δ	62003-2
INSULATION RANGE	WIRE SIZE	MATING TAB THICKNESS	-	62003-1
DO NOT SCALE PRINT. UNLESS SPECIFIED DIMENSIONS IN mm [INCHES] TOLERANCES ON: 2 PLC DEC ± 0.38 [.015] 3 PLC DEC ± - ANGLES ± -	DR 5/16/95 JR RUTH CHK 5/16/95 MS FEHER APPD 5/16/95 P DESANTIS APPD 5/16/95 R REINER PRODUCT SPEC -	AMP AMP Incorporated Harrisburg, PA 17105-3608		
MATERIAL H04 BRASS	FINISH SEE TABLE	NAME RECEPTACLE, FASTON, PIGGYBACK, 2.79 [.110] SERIES		
		SIZE B	CAGE CODE 00779	DRAWING NO C-62003
		SCALE 5:1	SHEET 1 OF 1	